

International Design Project 2018

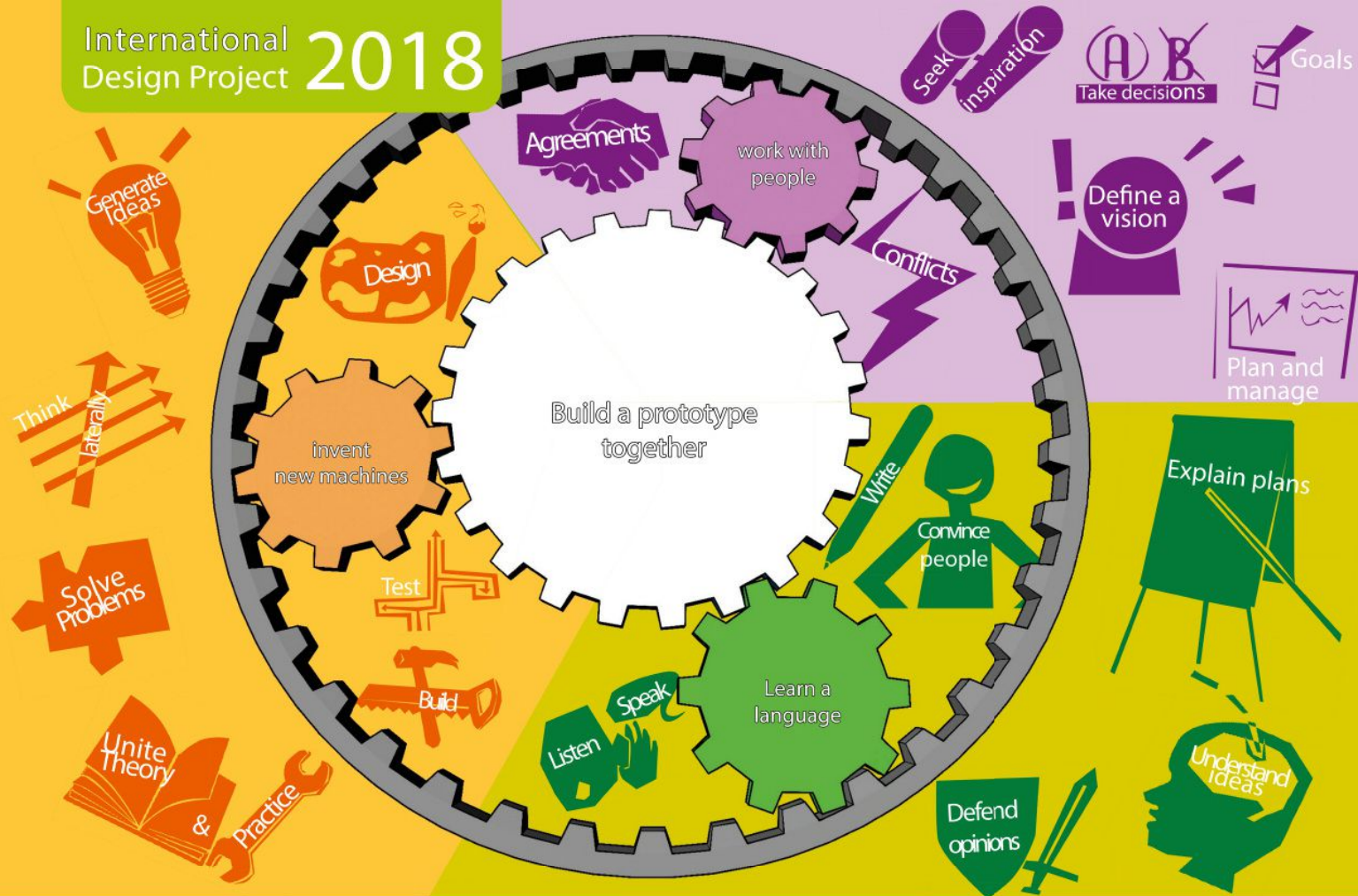



Leibniz Universität Hannover
Peter the Great St. Petersburg Polytechnic University

International Design Project 2018

Project Book

Supervisors

Christopher Tidy Polina Dyatlova

Assistants

Malek Al Jaber Svenja Fabisiak



Introduction

Developed countries are designing, building and consuming products faster than ever before. A near-limitless spectrum of devices – from cars to telephones – are becoming smaller, faster, cleaner and more versatile. The average person has more possessions and spends more hours interacting with manufactured products than at any other time in history. These products allow a company director to close deals, a mechanic to diagnose faults and a surveyor to gather data – all with increasing speed and ease. But they are also expensive, complex and difficult to understand, which raises a critical new question. What about the people who are left behind? The school in a poorer country, without the benefit of a science laboratory, the family without electricity, or the farmer who can't fathom a new tractor's software? How can one innovate where the experts and resources run dry?

The International Design Project gives engineering students the opportunity to consider this question in a team, working together to design, build and test a prototype for a developing country. The prototype must combine different technologies, use reclaimed materials and be feasible with little money. Students identify the materials, skills and tools available locally and design a sustainable product which can be built, modified and repaired without spare parts or manufacturer support. The project develops skills in three key areas. Firstly, it enables students to apply theoretical knowledge to a real-life design project, investigating manufacturing, reliability, optimisation and design compromises. Secondly, it gives students the chance to develop their team skills, working together to solve problems and reach agreements. Lastly, the whole project takes place in English, encouraging each student to find the terminology and confidence needed to express their ideas in a foreign language.

The project is offered co-operatively by Leibniz Universität Hannover and Peter the Great St. Petersburg Polytechnic University. In 2018, it took place over a period of four months, with teams working in both Hannover and St. Petersburg, and culminated in the exhibition of the prototypes at the Maker Faire Hannover 2018.

Each student team documented their work in their own way. This project book is the result.

Christopher Tidy Polina Dyatlova



Projects built in Hannover

Team 1

Ryan George
Hauke Heeren
Ba Dat Pham

Team 2

Yihui Wu
Klea Xhyra
Vivian Yap

Team 3

Marc Drewing
Khaoula Missaoui
Talia Sari
Tongsheng Wan

Team 4

Marcial Ndassi
Dorra Oueslati
Hutomo Saleh
Peter Walsch



2018

BBQler - Barbecooler

INTERNATIONAL DESIGN PROJECT

Pham, Ba Dat; George, Ryan; Heeren, Hauke

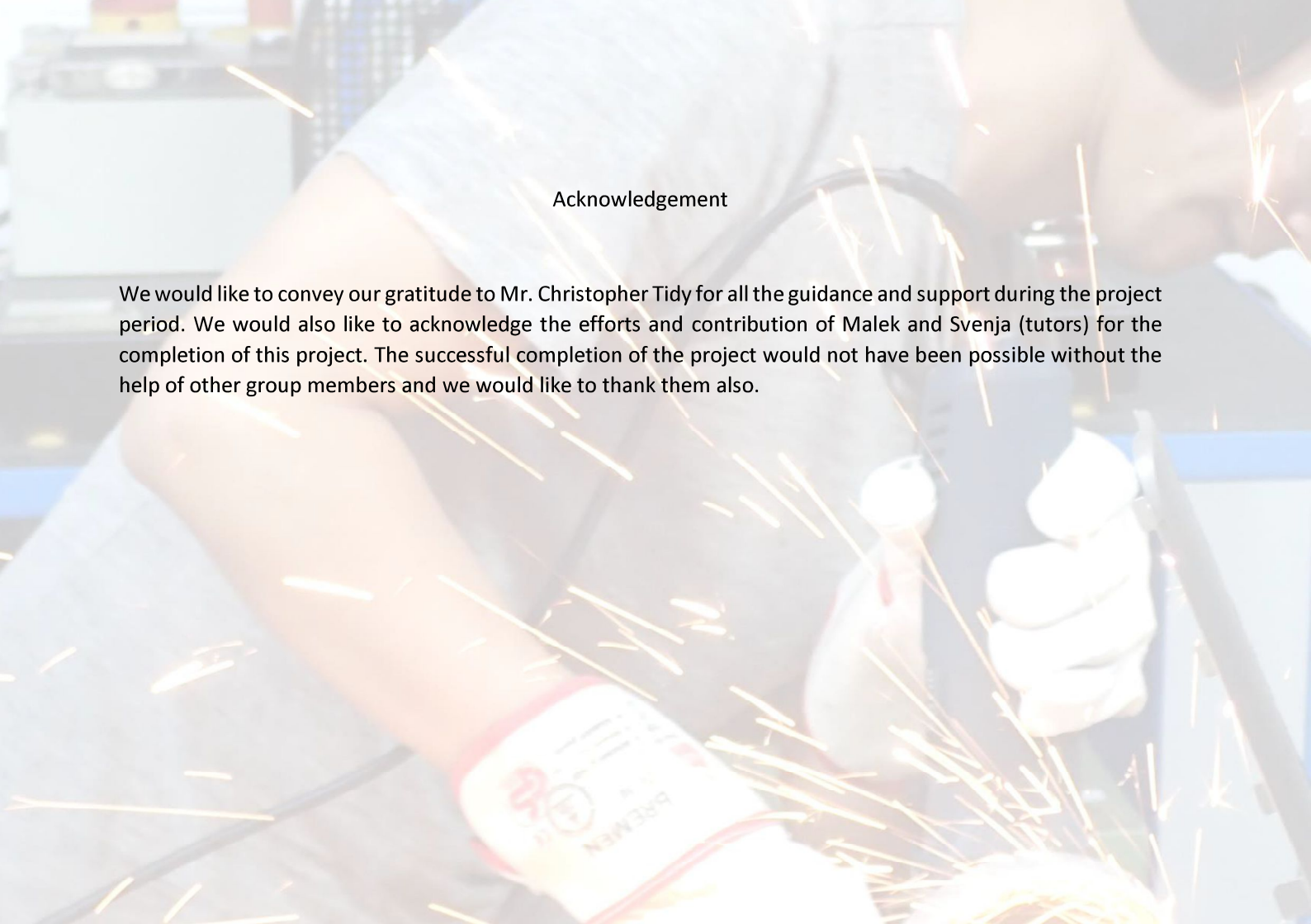

Acknowledgement

We would like to convey our gratitude to Mr. Christopher Tidy for all the guidance and support during the project period. We would also like to acknowledge the efforts and contribution of Malek and Svenja (tutors) for the completion of this project. The successful completion of the project would not have been possible without the help of other group members and we would like to thank them also.

1. Peltier elements

A Peltier element can either be used to generate electrical power from a heat difference between the two sides, or to create a heat difference by connecting the element to an electrical power supply.

1.1 Schematic

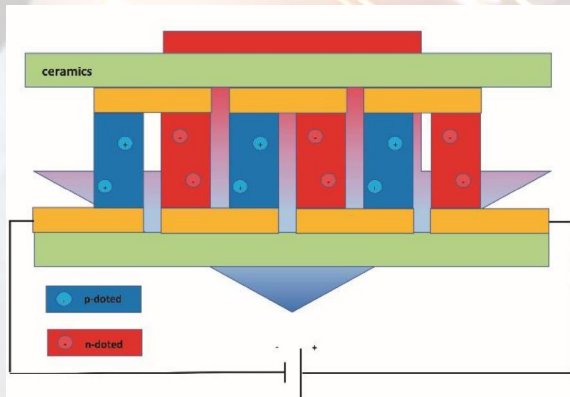

A Peltier element consists of n- and p-doped materials, which are connected in series.

Figure 1: Schematic of a Peltier element

1.2 Operating principle

The temperature gradient is generated by electrons switching between the different energy levels of the materials. Because one level is higher than the other, the electron needs additional energy to switch energy levels. This energy is absorbed from the environment. Therefore, the environment gets cooled. On the other side of the element the environment gets heated up.

The same principle is used to generate a voltage if there is a temperature difference between the two sides.

2. Project

2.1 General idea of the project

For our project we had the task of building something which is useful in developing countries.

Because there is a lack of electrical energy in developing countries, we decided to focus on this field.

This is how we came to the idea of using heat to power a small fridge. The power is generated by Peltier elements and the fridge also gets cooled by Peltier elements. Alternatively, you could use the power to charge your phone.

2.2 Steps of our project

2.2.1 Drawings

First, we did some drawings. For this we measured the size of a beer can to fit inside the cool box.

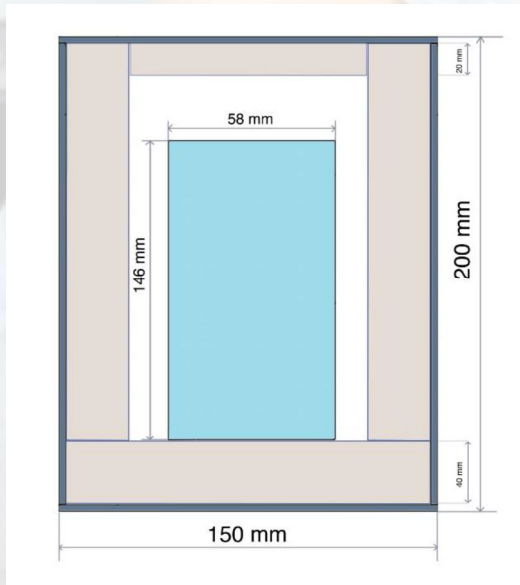

Figure 2: Measurements of the cool box

2.2.2 Testing

After we got our Peltier elements, we had to test them to measure the voltage generated and how much heat we needed. For this we used a heat gun and an infrared thermometer.



Figure 3: Peltier elements



Figure 4: Measurement with a heat gun

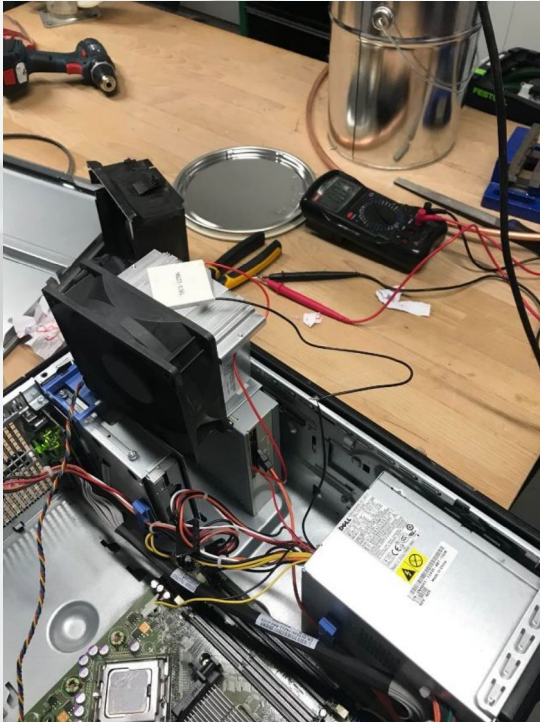

To test if the elements are working and cooling properly, we scrapped an old computer for the DC power supply.

Figure 5: Old computer

2.2.3 Building a “sandwich”

To spread the heat evenly, we decided to put the Peltier elements between two aluminum sheets.

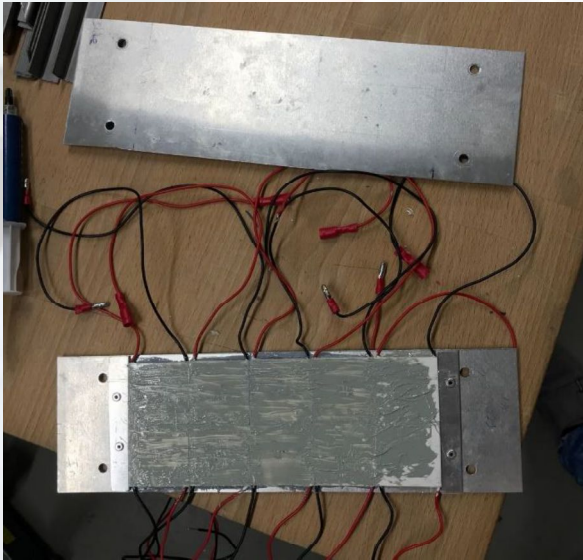

Figure 6: Thermal paste is used to improve heat conduction

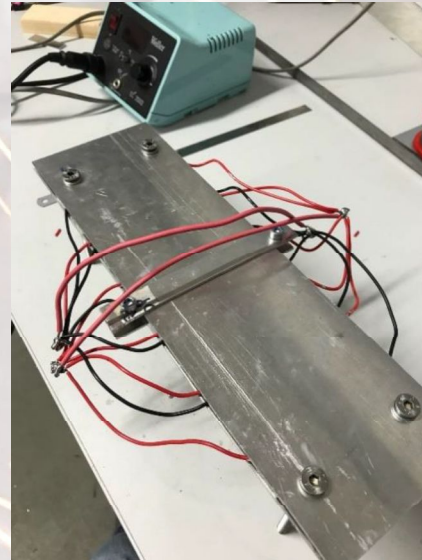

Figure 7: The finished "sandwich"

2.2.4 Building the fridge

For the fridge we used the cases of old computers.

First, we had to cut them to the right sizes.



Figure 8: Using the angle grinder

Afterwards, we joined them together with the help of aluminium angles, which we connected with rivets. The inside of the box is made out of polystyrene foam for insulation (see pictures below).

The heatsink for the Peltier element is connected to the lid of the cooler.

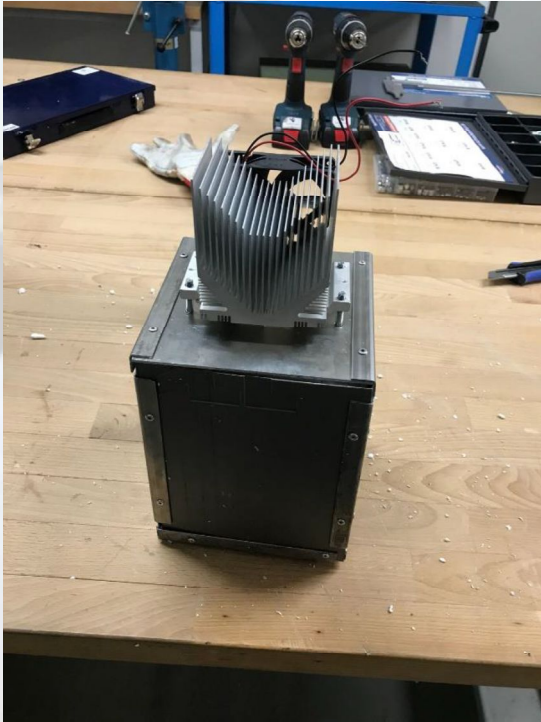

Figure 9: Finished cooling box

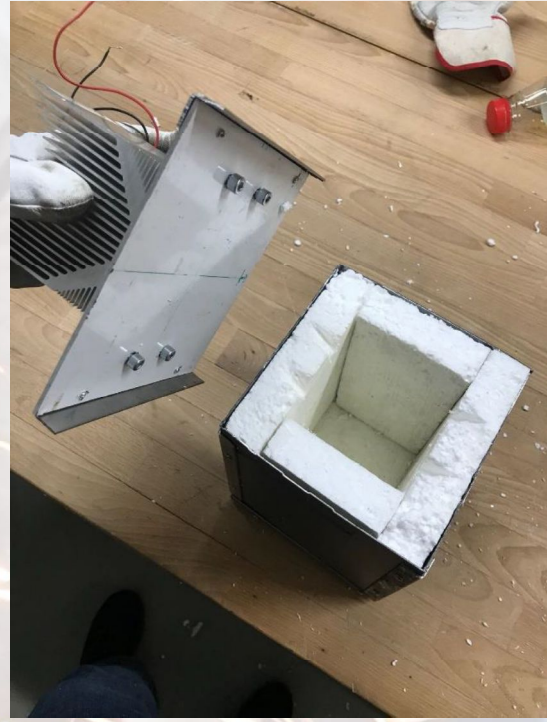

Figure 10: Inside of the box

2.2.5 Testing the fridge



Figure 11: Ice on the surface of the heatsink

The heatsink on the inside reached below 0 °C temperatures, which is cold enough to cool a beverage.

2.2.6 Building the barbecue



Figure 12: BBQ with grill plate

For the barbecue, we decided to use an old computer case. We stripped the computer of its internal parts and all the plastic.

Afterwards we attached the “sandwich” to the bottom of the case for the best heat transfer.



Figure 13: Mounted Peltier elements on the case

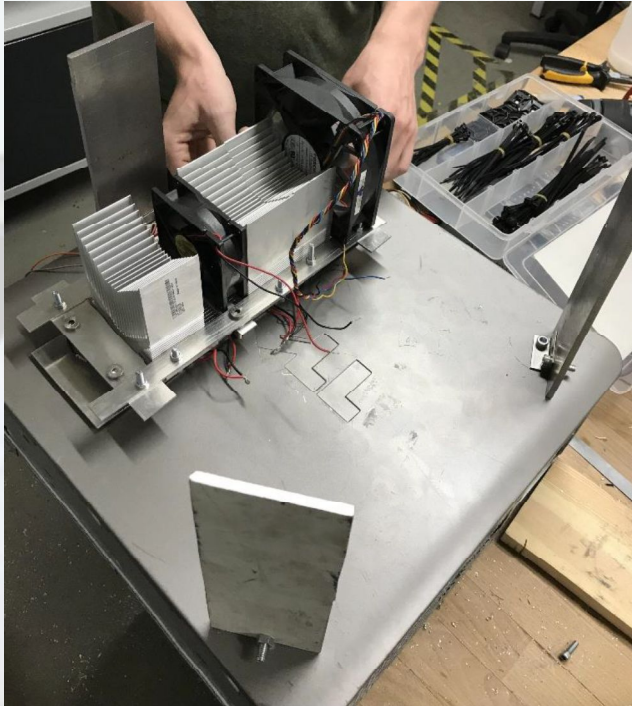

Figure 14: Heat sinks on the cold side of the elements

Because we had to attach the heatsinks, we created a rig to hold them in place. Also, we attached fans with the help of cable ties for active cooling.

3. Maker Faire



Figure 15: The setup at the Maker Faire





Figure 16: Explaining the prototype

On the first day of the Maker Faire we explained our project to children.

Because of their lack of understanding a few concepts, we had to explain our project in simple words.

This was just a “warm-up” for the next two days, when people with proper technical knowledge came to the fair.



Figure 17: Explaining our projects



Figure 18: Group picture at the Maker Faire

4. Final test



Figure 19: First time lighting up the grill

For our final test, we had a barbecue after the Maker Faire with the whole project group.

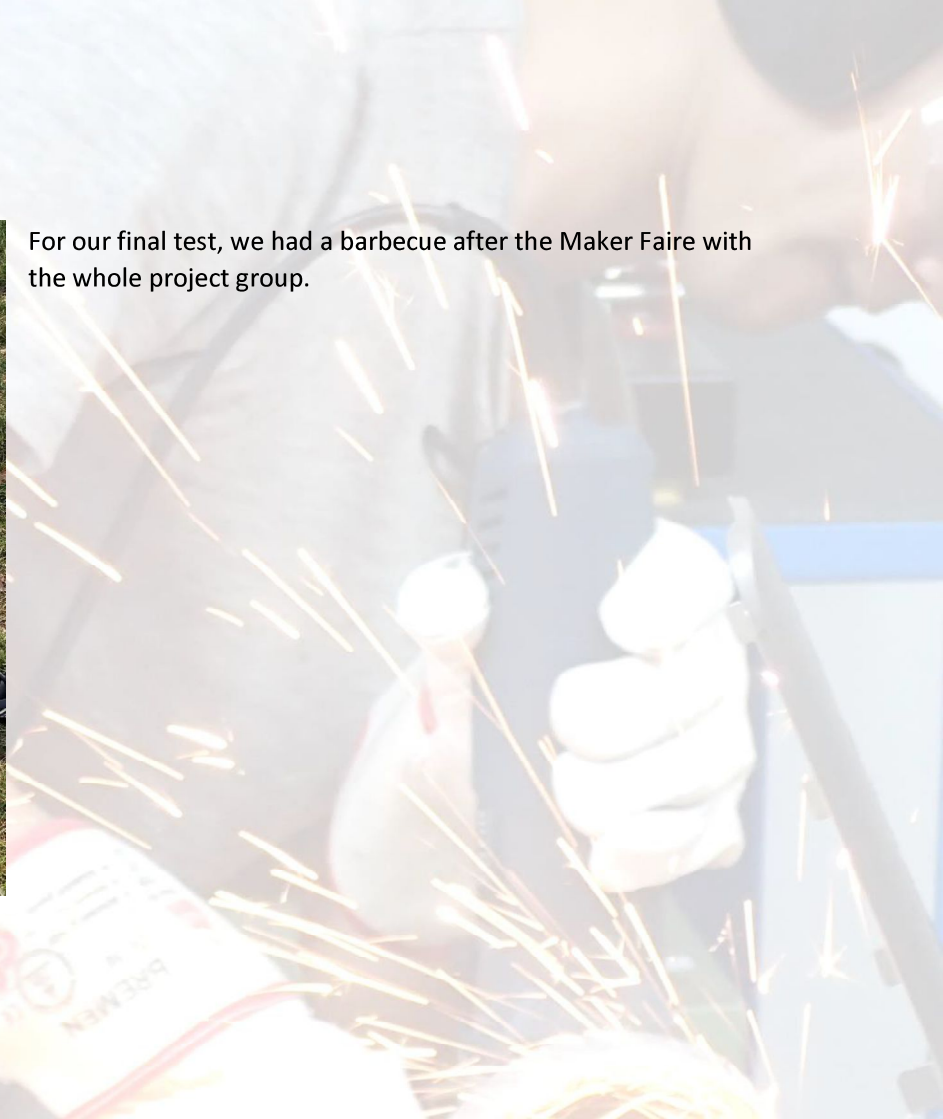



Our fridge is multi-functional and holds the grill tongs perfectly.

Figure 20: Tongs on the fridge



Figure 21: We are getting a voltage!

We got a voltage!

This was at the beginning of the barbecue, but because we accidentally ripped out some wires, we were not able to keep measuring.



Killing time while waiting for the meat to cook on the grill. We played frisbee!

Figure 22: Playing frisbee



Figure 23: Molten plastic

Apparently, we forgot to strip all plastic components from the old computer case. We only realized this when we tried the barbecooler for the first time. The plastic parts got badly burnt and emitted white smoke with a bad smell.



Figure 24: First grilled food

But still: the food was delicious.



Figure 25: Grilled poultry meat

It has been a pleasure for us, and we hope for you too! Bye!



Figure 26: Group picture

International Design Project 2018

Leibniz University Hannover

Team 2 (Washer Roller)



**Ladybird
(Washer Roller)**

Team 2

Lei Cheng, Yap (Vivian)

Yihui, Wu

Klea Xhyra

Content

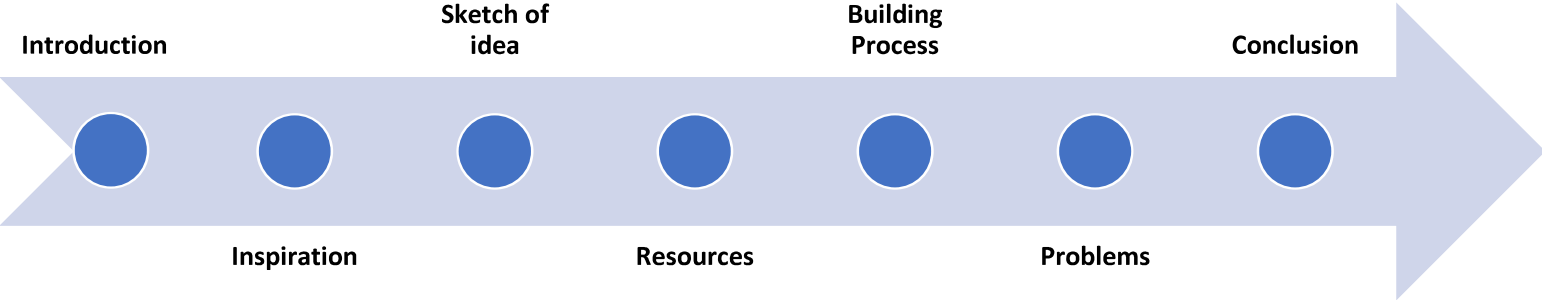

Introduction

**Sketch of
idea**

**Building
Process**

Conclusion

Inspiration

Resources

Problems

First Day in class



Hello, I am Mr Tidy. I want you guys to think about what types of design can be assembled and repaired in communities where tools, money and infrastructure are scarce ?

Can fresh thinking and reused materials deliver a product which benefits both people and the environment in developing countries?

First Meeting



First Meeting

However, we don't have a place to test the generator in Hannover.

I think we can make a hydroelectric generator as most of the rural areas don't have electricity

I have an idea !
What about a washing machine ?



Inspiration



Caretakers of large households from developing countries often have difficulties managing the oversized amount of laundry. Younger members often are unable to help out due to their own workload, which they take on in order to support their family financially. Used washing machines can be reconstructed, in order to function without electricity. It can be operated by attaching a bicycle pedal.



First sketch

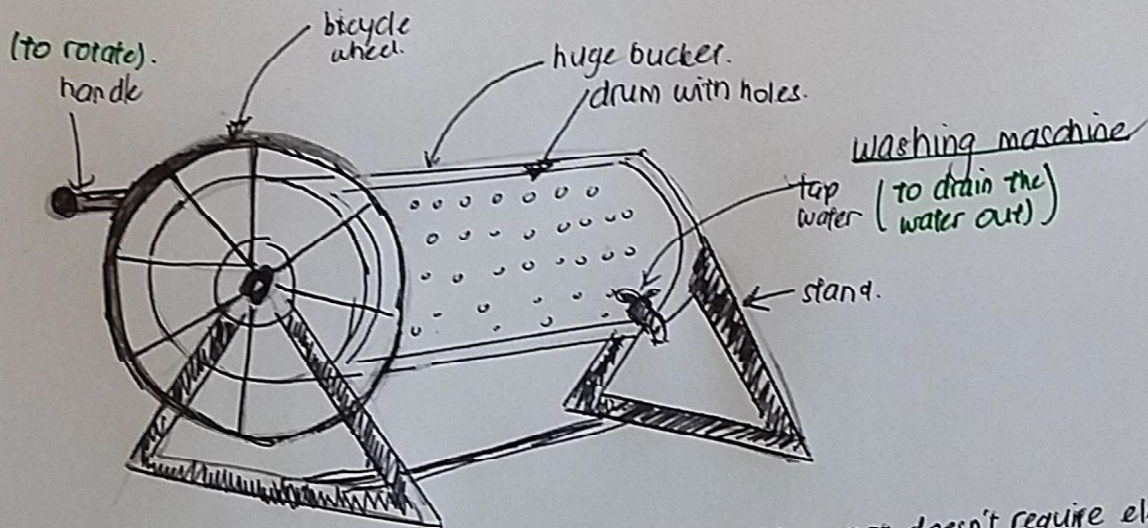

Goal: provide ^{poor} families a self rotating ~~star~~ washing machine that doesn't require electricity.

Problem: Some families have large amount of laundry everyday. It is a hustle to wash all of it by hand. In some cases, they always have to bend over to wash their clothes by hand on the floor and it causes ~~to~~ back pain as well.

Initial Draft

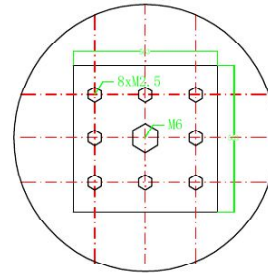
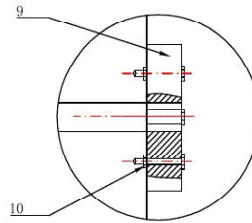
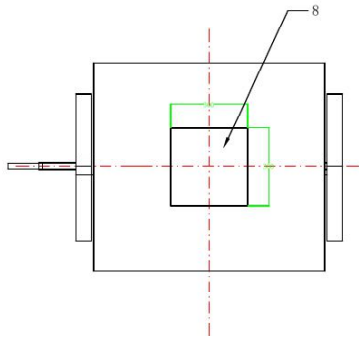
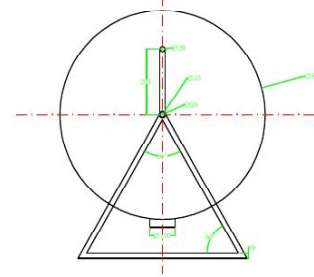
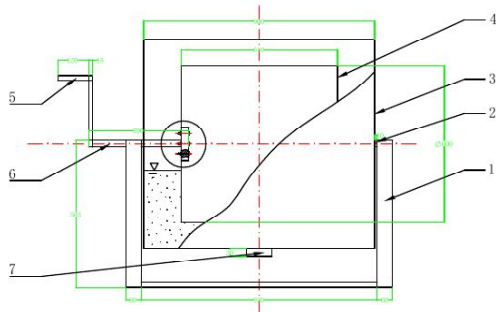

10	Screw nuts	8	Metal	1:1
9	Connection hole	1	Wooden	1:1
8	Door	1	Metal	1:1
7	Water outlet	1	Metal	1:1
6	Sliger-Stick	1	Metal	1:1
5	Handle	1	Metal	1:1
4	Washing drum	1	Metal	1:1
3	Container	1	Metal	1:1
2	smaller Stick	1	Metal	1:1
1	Stand	1	Wooden	1:1
Nr.	Name	Amount	Material	Proportion

Washing Machine		Proportion	1:1
Drawing Maker	Yihui Wu	Design Project Team 3	
Date	07.01.2018		

Material

Viv : Let's gather the material then !

Klea : I found something on Ebay ! And we can get it for free.



Waschmaschine
Zu verschenken

Mr Tidy : Maybe you guys can have a look at the dump site behind the institute.

Wu : We found a bike earlier today !

Material



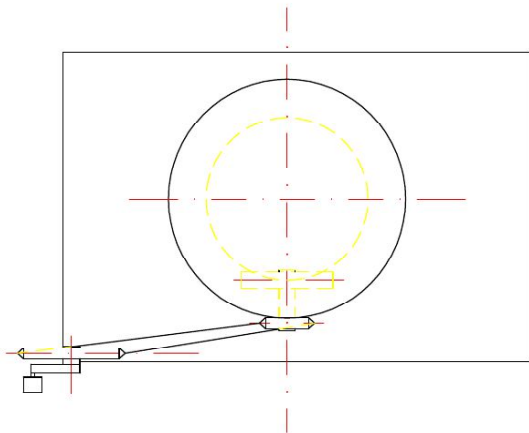
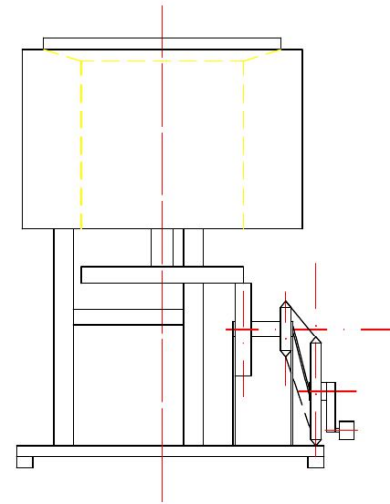
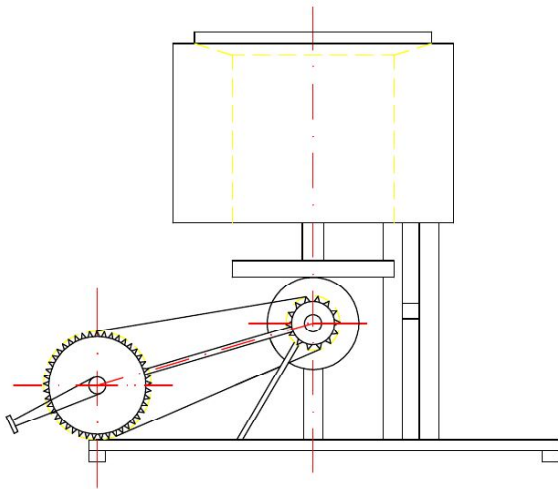

Viv : Let's draw the final draft



Project Design		Proportion	1:5
Drawing	Team 3	Washer Roller	
Date	10.09.2018		

Building Process

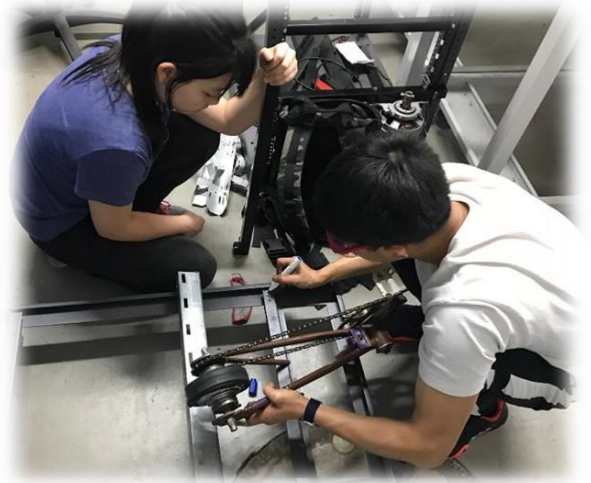
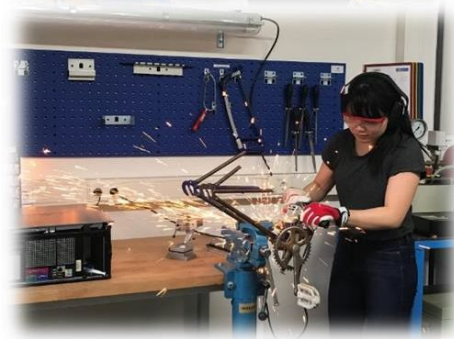

Problems

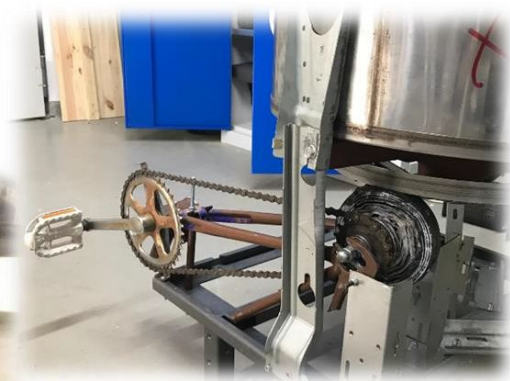

The structure wasn't sturdy enough



Problems



Roller made of used tire slipped off



Problems

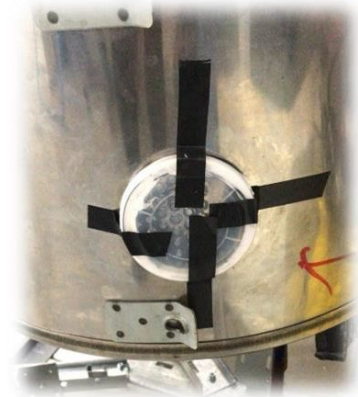
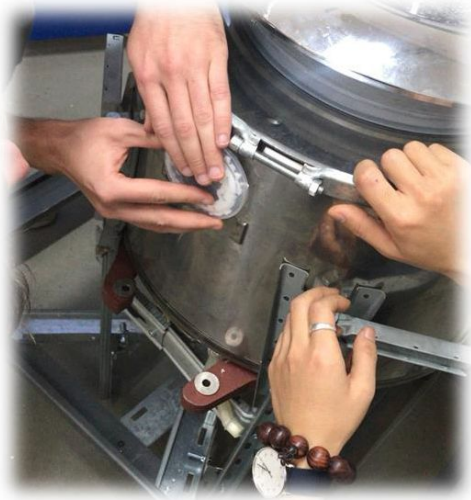

Holes on the drum were not properly sealed.



Pros and Cons



It is affordable and it works without electricity.

It is not durable and not efficient.



The ladybird

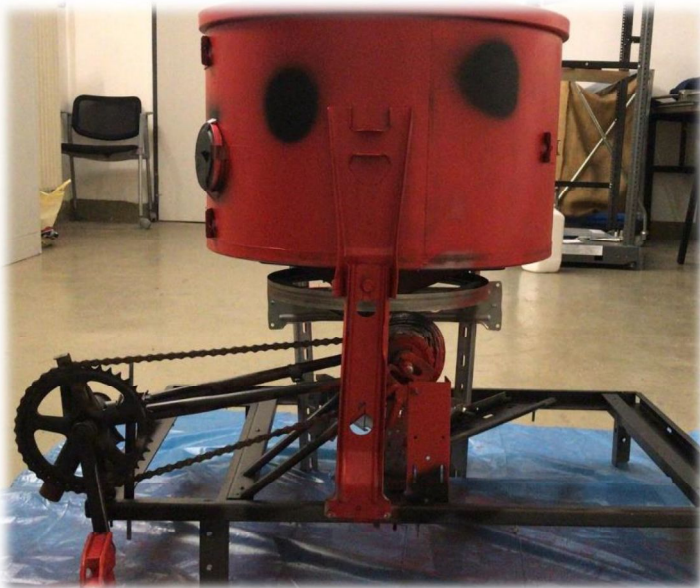

Name	The ladybird
Cost	€ 32
Material	Mostly Reused



Prototype tested

Conclusion

Although we come from different experiences and backgrounds, we've managed to overcome several obstacles together and make it work. Participants in this project were very encouraging, helpful and generous with their skills and knowledge. Overall, it has been an amazing journey to be able to participate in this project.



PEA.ZA TOWER

11
102
1004

Leibniz
Universität
Hannover

INTERNATIONAL
DESIGN
PROJECT

20
18

GROUP 3

MARC DREWING
KHAOULA MISSAOUI
TALIA SARI
TONGSHENG WAN

Pea.za Tower

is designed to help locals grow food easily without taking a lot of space and gives the plants access to maximum sunlight.

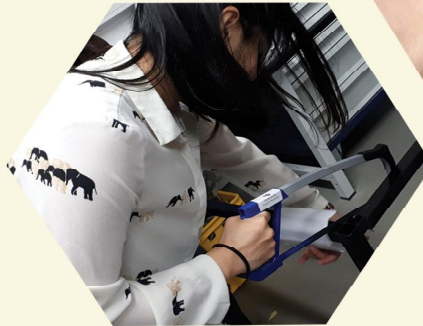



Pea.za Tower

moves automatically depending on where the most light comes from, so that photosynthesis can occur for the most hours of sunlight. It is built with mostly reused materials.

MATERIALS

Materials	Number	Source
Container	4	Chemistry Department
Stand: - Wooden Planks - Server Rack	2 1	Baumarkt (DIY Warehouse) TFD Faculty
Wood to lift the wooden plank up and down	1	Baumarkt (DIY Warehouse)
Spring	4	Mechatronic Faculty
Threaded Rod	1	Baumarkt (DIY Warehouse)
Screws		
Motor	1	Old Washing Machine
Metal parts to build connections		Scrap
Electronic Components (Transistors, Resistors, Cables, etc)	1	Desolder from old parts and Baumarkt
Acrylic Glass	2	Baumarkt (DIY Warehouse)

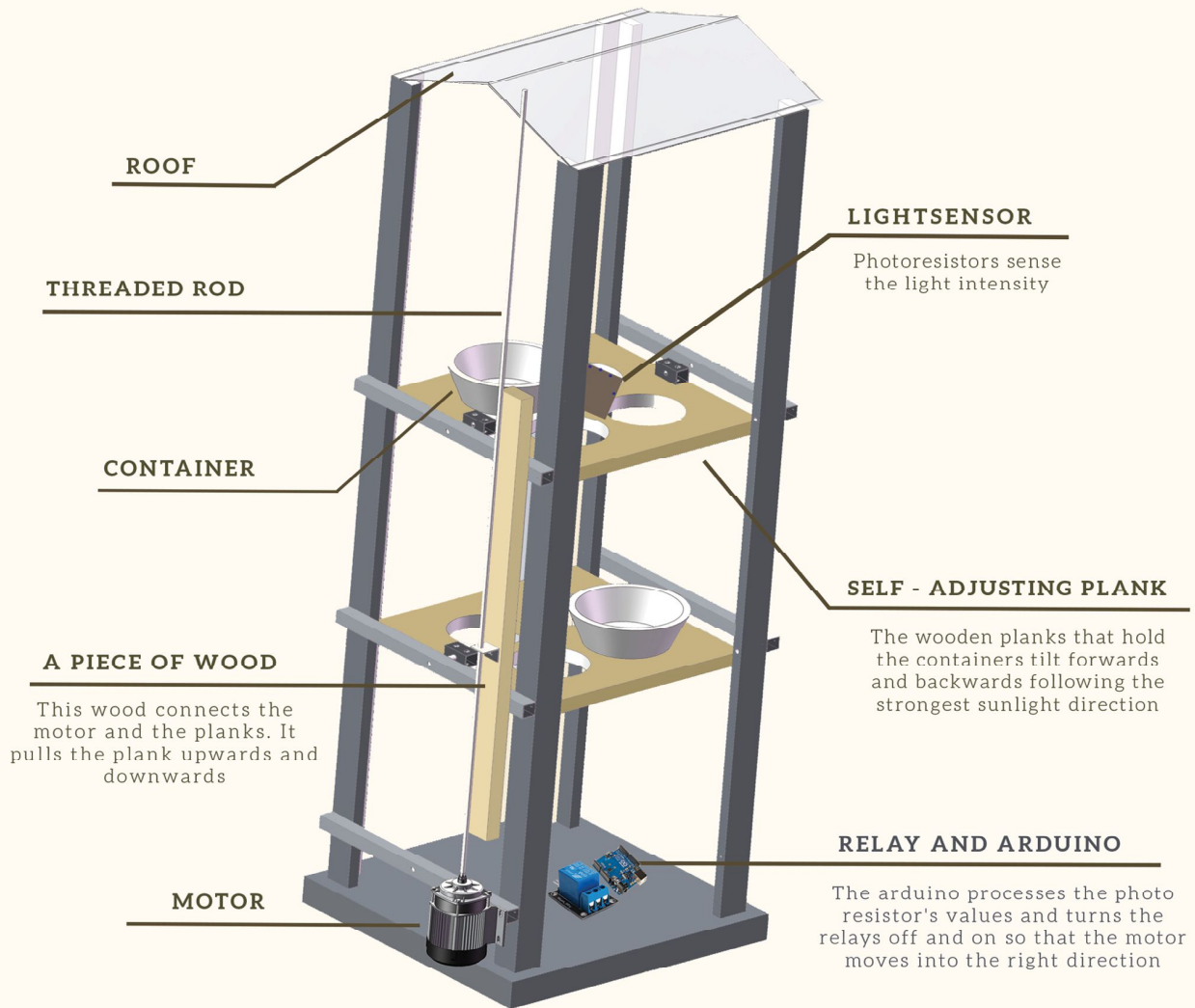

PROBLEMS DURING THE PROJECT

During the project, not everything worked as we expected. First of all, we had no access to a welding machine, which we would have needed to build the bearings according to the original plan. So we used a much simpler method instead: screws and drilled pieces of metal scrap replaced the complicated first version of the bearings. But due to the simplicity, the screws were not able to withstand great forces. So we needed to change the container for the plants. Even though we got a metal barrel, it proved too difficult to use, as the barrel alone was pretty heavy. Together with the weight of the wet soil in the volume of the barrel, it would have been way too much for the bearings and server rack.

Another major detail we needed to change was the mechanism that was supposed to turn the planks of the tower towards the sun. We wanted to recycle bicycle chains and gears for this purpose, but we had problems attaching the gears to the planks. In addition, the bicycle chains we got were way too short and we didn't have the tools to connect the chains in order to reach the length we needed. This was actually a really big problem since the mechanism was a major component in our project. We noticed this after we had already made a lot of progress, so we needed to think of something that would fit into the place of the original concept. After many discussions with the leader of the IDP and the technical assistants, we decided to use what ended up in the finished prototype.

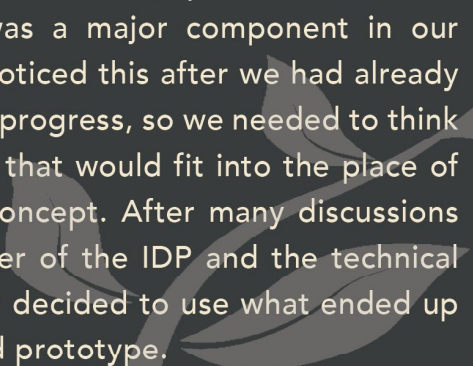

PROBLEMS DURING THE PROJECT

Even though we found a solution in the end, we wasted a lot of time. So time was another big issue. All team members worked all day long during the last days before we got to the point where our Peaza Tower was ready to display at the Maker Faire. Even though we tried hard, we could not finish our project on the last day. While preparing the hall where we would be displaying our projects, we were still soldering and working on the prototype. Even half a day into the Maker Faire, it was necessary to complete debugging and adjusting the program until our prototype was finally finished.

Especially since we could not plan ahead using standard parts for our project, we had to adjust our plans constantly. Managing time and resources meant problems all the way to the finished prototype. Thinking back, we really should have taken the warnings seriously. Always be prepared for problems to appear!



The sun is very strong and the weather stays warm for a long time so plants can be grown constantly.

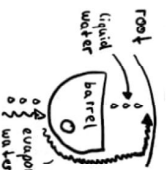

parts of the water collect under the feet and is guided back. The root is in the form of a barrel. The barrel's top and bottom are removed and the barrel is made flat so it collects more water.

Water is guided back with a chain.

Water evaporates

Sun
photo transistors/resistors measure when direction is the brightest

salad or other vegetables

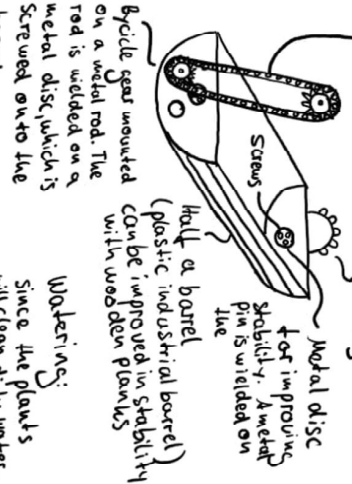

Watering:
since the plants will clean dirty water, no drinking water has to be used for watering

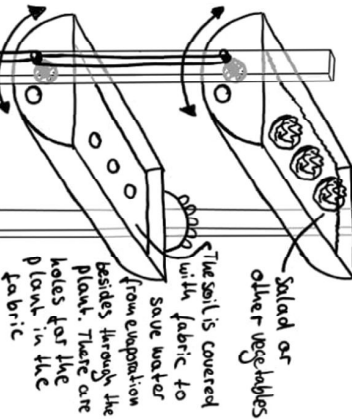

Stands for the barrels. Can be made of any material, wood would be the easiest to work with.

in a far turns the bicycle gears and the gears reduce speed on tilting the barrels to the right side and towards the sun so the plants get the most light.

(simple transistors make the barrel turn until the outer photo resistors have a higher resistance than the middle one)

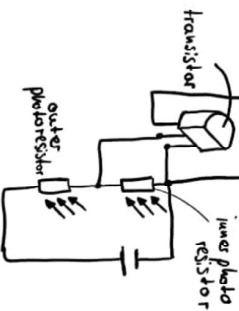

If the outer photo resistor has a lower resistance, it means the positioning is not correct and the voltage drop over the inner resistor is higher. Since the transistor is parallel to the

inner transistor, it's voltage will also increase which will activate the transistors and therefore activate the motor for tilting.

in case it doesn't work properly in the prototype: use Arduino

The sun is very strong and the weather stays warm for a long time so plants can be grown instantly.

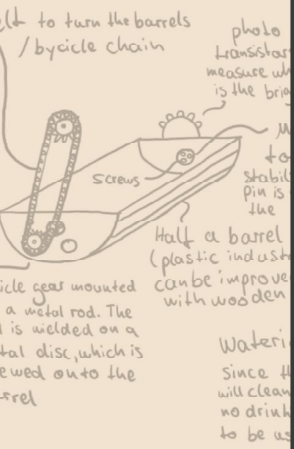

motor turns the bicycle gear and the gears reduce speed on tilting the barrels to the side and towards the sun so the plants get the most light.

simple transistors make the barrel turn until the outer photo-resistors have a higher resistance than the middle one.

In case doesn't work properly in prototype: Since the transistor...

This was the first sketch of our prototype. Since the construction of the prototype didn't go as we planned, we had to find other solutions. We eventually used liquid containers from the chemistry department's garbage as the plant containers, since they are lighter and strong. We nailed them to a wooden plank that we bought from a store. For the light sensor, we used five photo-resistors that are glued onto a small semicircular piece of wood and mounted on the highest level. The sensor detects the direction from which the strongest sunlight is coming. A used washing machine motor spins a threaded rod that is attached to a long wooden post and a spring is needed on each level of the tower to connect the wooden post and wooden plank. The rotation of the motor switches automatically between barrels to the clockwise, off and anticlockwise, and this is achieved using a relay and Arduino program. The rod moves the wooden post and the attached springs tilt the planks up and down. We also screwed two limit switches onto every plank to limit the rotation. The prototype has a transparent roof made from acrylic glass.

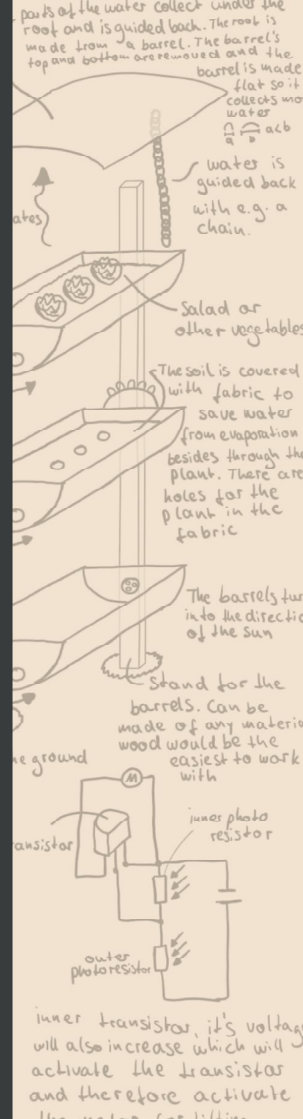

EVALUATION OF SUCCESS



We managed to finish our project at the last minute. We spent whole days before the Maker Faire in the workshop and even after we took our prototype to the fair, we had to do some soldering and programming. We were the last team to finish. It was a bit stressful but at least the prototype worked successfully in the end. The wooden planks tilted toward the strongest sunlight direction just as planned.

We filled the pots with some plants and brought a small torch to demonstrate how it works. Sometimes we'd let people use their phone torches to make our stand more interactive and fun.

The first day of the Maker Faire was the kids' day. We got more attention the second day. A lot of people showed interest in our prototype. They were amused by the tilting of the planks; they would stop in front of our stand, ask questions about everything, and take pictures and videos. We even got a business card from a company who wanted to know some details about the prototype.



ARDUINO PROGRAM

```
#define sensor1 2 //connecting the pins to the correct sensors
#define sensor2 3
#define sensor3 1
#define sensor4 0
#define sensor5 4

void setup() {
  pinMode(6, OUTPUT); //POWER Power LOW means LOW
    //referred to as relay 1 in diagram
  pinMode(2, OUTPUT); //Direction (needs to be in same state as pin 3!!)
    //referred to as relay 2 in diagram
  pinMode(3, OUTPUT); //Direction (needs to be in same state as pin 2!!)
    //referred to as relay 3 in diagram
  pinMode(4, OUTPUT); //use for something else
  pinMode(5, OUTPUT); //use for something else
    // 2 and 3 HIGH --> UP
    // 2 and 3 LOW --> DOWN
  Serial.begin(9600);
}

void loop() {

  byte richtung = sensor(); //execute the sensor method to measure
    //where the light is coming from
  if(richtung==1&&) { digitalWrite(6, LOW); //power for the motor disabled
    digitalWrite(2, LOW); //change direction to left
    digitalWrite(3, LOW); //change direction to left
    digitalWrite(6, HIGH); //power for the motor enabled
    delay(400); //motor turns for 0.4 seconds
    digitalWrite(6,LOW); //motor disabled
    Serial.println("turns left");}

  if(richtung==2) { digitalWrite(6, LOW); //power for the motor is disabled
    digitalWrite(2, HIGH); //change direction to right
    digitalWrite(3, HIGH); //change direction to right
    digitalWrite(6, HIGH); //power for the motor enabled
    delay(400); //motor turns for 0.4 seconds
    digitalWrite(6, LOW); //motor disabled
    Serial.println("turns right");}

}
```



```

byte sensor() {
  int s1 = 0;      //the sensor at the left
  int s2 = 0;      //second sensor from left
  int s3 = 0;      // middle sensor, third sensor from left
  int s4 = 0;      // second sensor from right, fourth sensor from left
  int s5 = 0;      // first sensor from right, fifth sensor from left

  int s1off = 120; //offset is changed so that every sensors
  int s2off = 120; //delivers about the same value for the same
  int s3off = 120; // amount of light it is receiving
  int s4off = 100;
  int s5off = 80;

  for(int z=0; z<20; z++) {          // -----
    s1 = s1+analogRead(sensor1);
    s2 = s2+analogRead(sensor2);    //averaging numbers
    s3 = s3+analogRead(sensor3);
    s4 = s4+analogRead(sensor4);
    s5 = s5+analogRead(sensor5);
    delay(20);
  }
  s1 = (s1/20)-s1off;                //reducing values by offset
  s2 = (s2/20)-s2off;
  s3 = (s3/20)-s3off;
  s4 = (s4/20)-s4off;
  s5 = (s5/20)-s5off;                // -----

  Serial.print("Sensor 1:");        // values of sensors are sent
  Serial.println(s1);               // to computer for debugging

  Serial.print("Sensor 2:");
  Serial.println(s2);

  Serial.print("Sensor 3:");
  Serial.println(s3);

  Serial.print("Sensor 4:");
  Serial.println(s4);

  Serial.print("Sensor 5:");
  Serial.println(s5);
  Serial.println("-----");

  if((s2>s3+20)&&((s2>s4)&&(s2>s5))|((s1>s4)&&(s1>s5))) { Serial.println("turn left"); return 1; }
  if((s4>s3+20)&&((s4>s2)&&(s4>s1))|((s5>s1)&&(s5>s2))) { Serial.println("turn right"); return 2; }

```

```
// comparing the sensors to decide which direction to turn. If both sides receive less light
// than the middle sensor or if both sides do receive about the same amount of light,
// than the planthouse stays the way it is and does not turn.
return 0;

}
```

EVAPOT 0.4

Evaporative Air Cooler

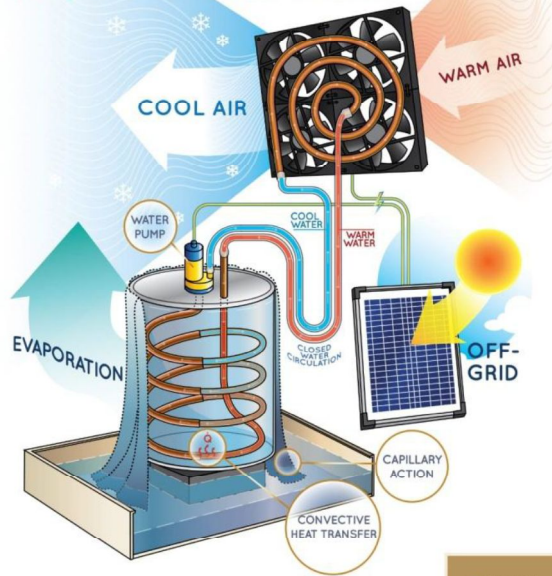

1024
Leibniz
Universität
Hannover

INTERNATIONAL
Design Project

2018

D. Oueslati
H. Saleh
M. Ndassi
P. Walsch

EVAPOT

Evaporative Air Cooler

Team 4

Dorra Oueslati
Hutomo Saleh
Marcial Ndassi
Peter Walsch



Blazing heat...

A glimmering horizon...

Sweaty clothes sticking to your skin...

We've got just the right solution for you!

The fully energy-self-sufficient
EVAPOT sweats for you, keeps you
chilled and lifts your spirit with a fresh
breeze.



On the following pages we describe the process that lead to the Evapot in the **International Design Project 2018**.



Maybe Mr Tidy just handed you this booklet and you are reading it in the kickoff-meeting for an IDP of the future. Then this document shall give you an impression what lays ahead of you and your fellow team mates.

Outline:

1. Gathering ideas and concepts
2. Concept evaluation and rating
3. Improvements to the chosen concept
4. Assembly
5. The Maker Faire

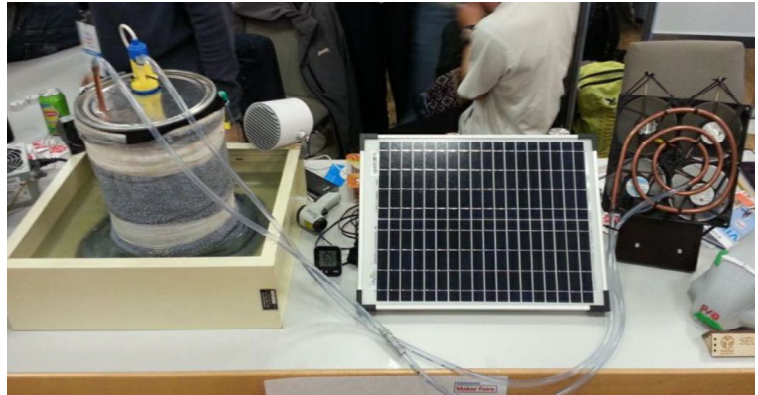
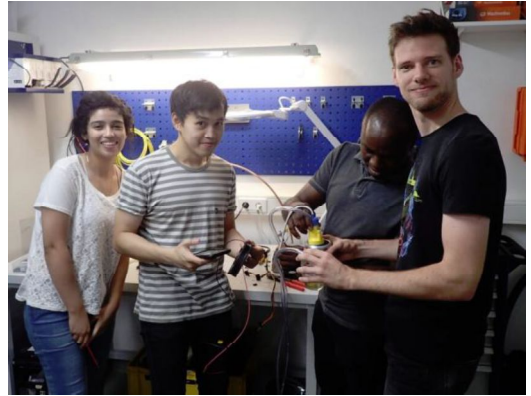

1. Gathering ideas and concepts:

The process of selecting this concept is rooted in the question we asked ourselves: what can we make with **reusable material** to help people in **developing countries**?

From this, we determined areas of direct impact on the population and the related difficulties. For us, the first area was the daily routine, the second the workplace and finally the environment.

With regard to the daily routine such as bathing, cooking, washing clothes, etc., we have identified a great potential for assistance ranging from access to clean drinking water to hot bathing water.

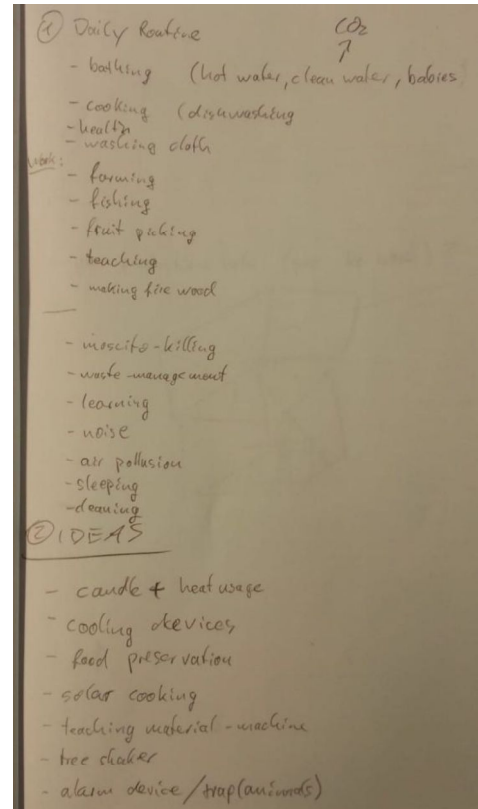

As far as the workplace is concerned, we thought about fishing, farming, picking fruits, teaching or lighting fires in remote areas. With regard to their living conditions, mosquito killing, waste management, noise management, pollution, cleaning or access to electricity were the targets. To invent and manufacture an aid to the population for one of these areas or activities would be very positive.

The next step was a brainstorming session to list concepts for a potential invention. Ideas regarding food preservation, solar cooking, **cooling devices**, small power plants, teaching materials, tree shakers, traps for mosquitos, and alarm devices were proposed.

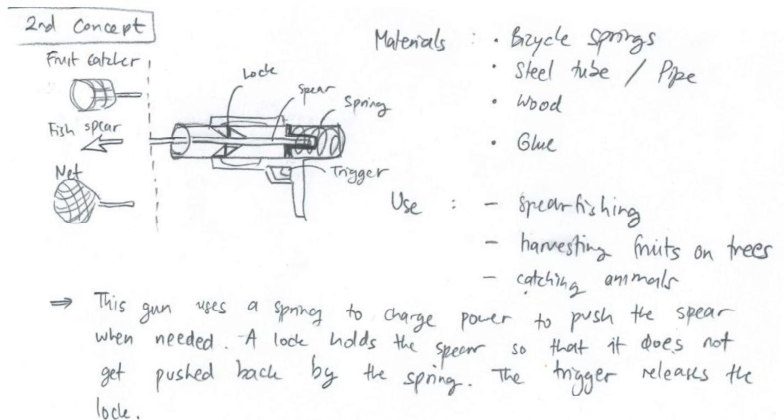

2. Concept evaluation and rating:

To compare and evaluate the concepts, we used a scoring system with five different criteria which were weighted differently:

- Availability and materials 15%
- Costs 20%
- Time needed for manufacturing 25%
- Skills needed for manufacturing 25%
- Impact 15%

Discussing every concept we rated them from 1 (poor) to 3 (very good) with regard to the criteria. The result was a score that could be used to compare the concepts. The results are shown on the next page.

Concepts

- 1- RPT (rice planting tool)
- 2- Stove +
- 3- Hero Fan
- 4- Alarm
- 5- spear gun
- 6- Hot Lamp
- 7- Hydropower (water falls, rain)
- 8- CoolPot

A	15
B	20
C	25
D	25
E	15
Σ	100%

	Criteria					Grade
	② Availability of Materials	⑤ Costs	④ Complexity of Manufacturing		⑥ Impact	
			(Time)	(Skills)		
1	②	②	①	①	③	1,55 1,7
2	③	②	②	①	②	
3	①	②	③	③	②	2,05
4	①	①	①	①	③	1,2
5	②	③	②	②	①	1,85
6	②	②	②	①	①	1,4
7	①	①	①	②	③	1,45
8	②	②	②	③	②	2,05

- ⑧ over ③ because
- ↳ ⑧: different & multiple purposes
 - ↳ flexible design
 - works with or without el. energy
 - ③: problematic availability of solar panel (③)
 - loading a battery
 - combination of concepts ③ & ⑧

As two similar concepts had the same maximum score, we combined both to form a winning concept. The PHreezDM, as we called it, was born. An ancient yet effective way to cool down food or water is the use of evaporative cooling (pot-in-pot-cooler; arabic: “zeer”). The PHreezDM combines this effect with a solar-powered fan. As a result you have a cooled air flow with just a small need for electric energy.

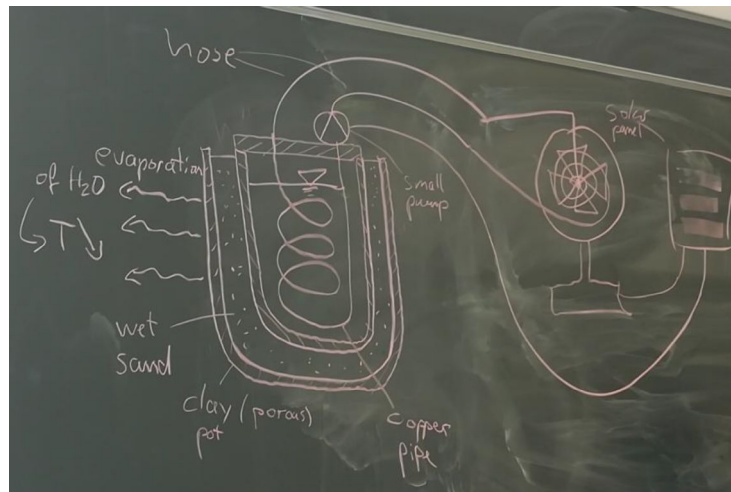

3. Improvements to the chosen concept

While talking about the chosen concept, we realised that the manufacturing of the two clay pots brings a lot of risk with it. While pottery was something that a lot of people knew how to do 2000 years ago today, we live in a different time. For we have no Harry, nobody in our team knows pottery.

So we decided to substitute the clay pot with a modern metal bucket, in this case a 30-litre paint tin. It would reduce the weight, increase the storage volume and thermal conductivity and especially make it easier to work with. To provide a big surface for evaporation, we wrapped an old terrycloth towel around the tin using an old cotton t-shirt as the contact layer and bandages to tighten it. The **EVAPOT** was born (named later).



PH1005 DM

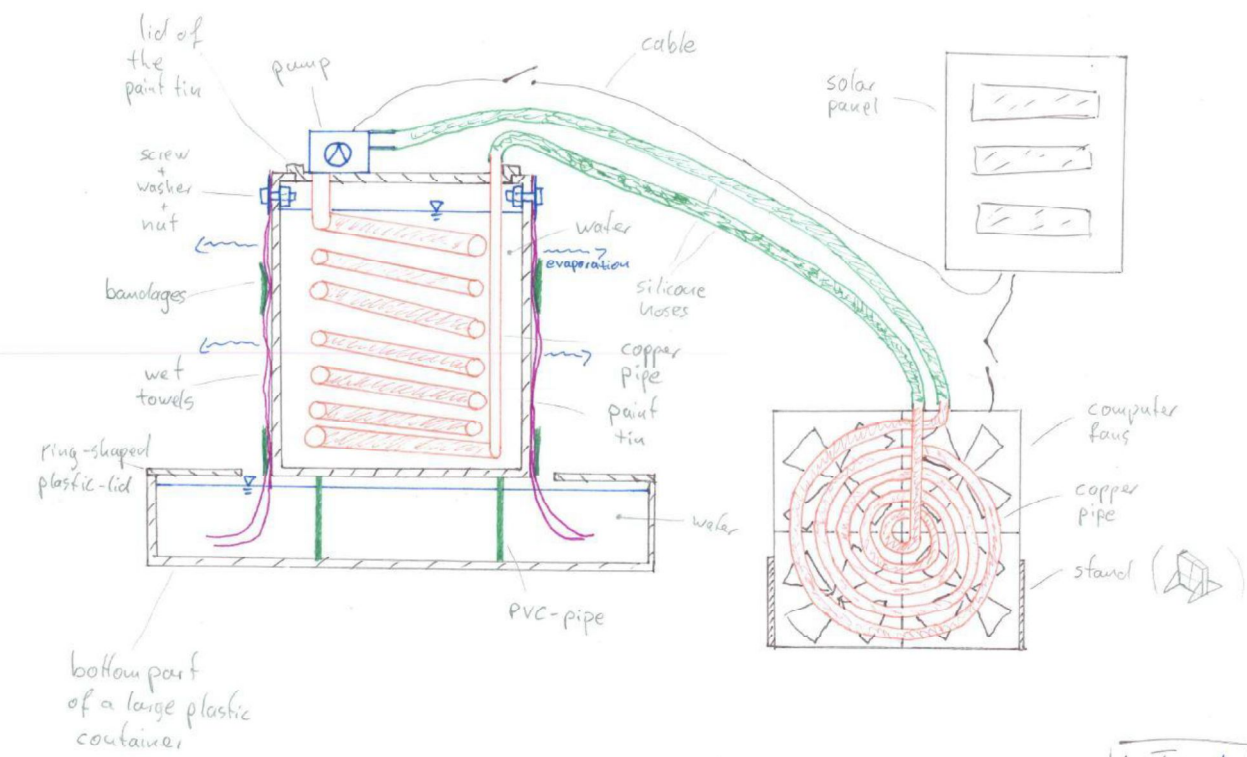

by Team 4

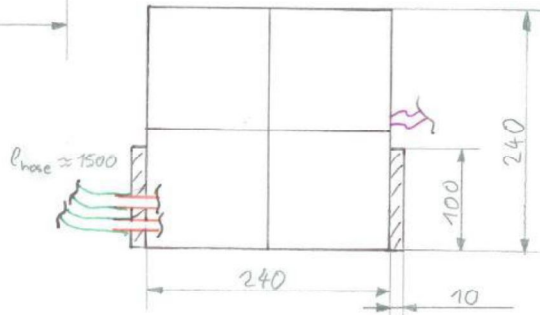
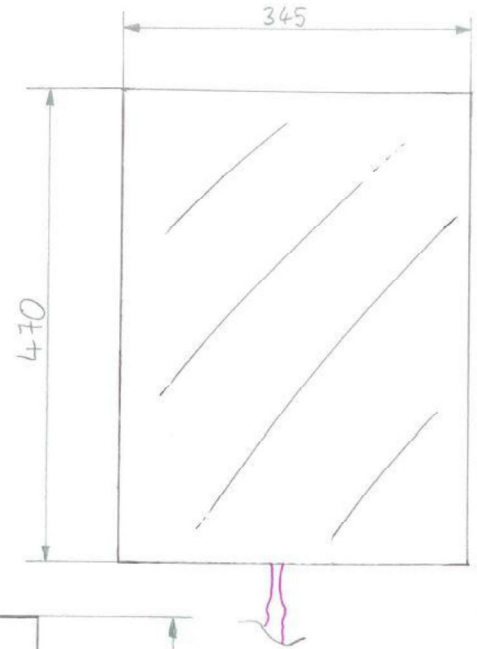
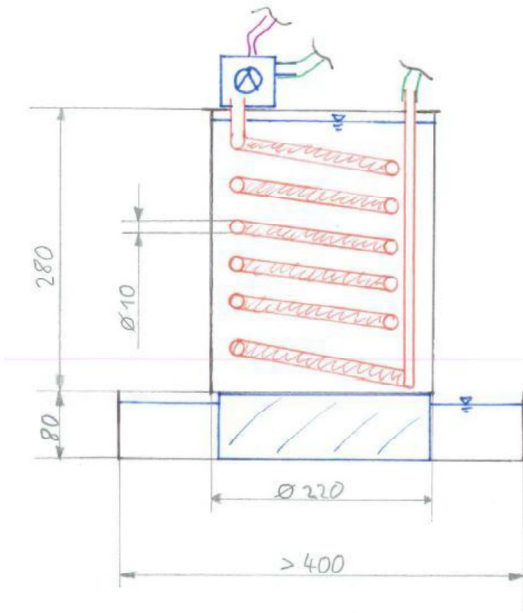

scale:	1:5
name:	PHrossDM
creator:	Team 4

4. Assembly

The EVAPOT

1. The copper pipe is bent into a cylindrical shape using a plastic wheel found in the workshop.
2. The T-shirt and towel are cut and measured precisely so they will fit tightly around the bucket. They are then stitched together.
3. Holes are drilled into the bucket. The cloths are taped temporarily to hold them in place. The cloths are also drilled through for the nuts and screws.



4. The cloths are then screwed in place and tightened with bandages to reduce the amount of air between layers.
5. The lid of the bucket is drilled for the outlet of the copper wires.



Pump Assembly

1. Because the copper pipe does not fit the pump, a custom pump inlet is made from a copper plate and a short copper pipe. It is then glued to the pump.
2. The pump is then tested using the plastic hose to make sure it's leak proof.
3. The pump is mounted on top of the bucket lid using glue and reinforced with cable ties.
4. The plastic hose is connected to the pump outlet. The other end of the copper pipe is also connected to a plastic hose.

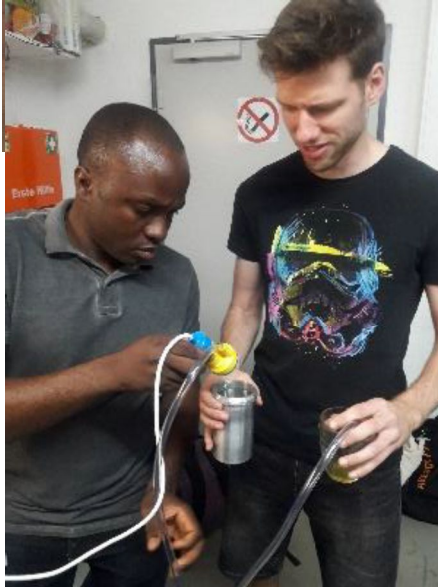

Fans & Solar Panel Assembly

1. Four fans and one power adaptor are retrieved from used computer base units.
2. Fans are set up in a parallel circuit with the solar panel as their main power source. The pump is also in parallel with the fans.
3. The fans are mounted on a used metal frame with cable ties from a bicycle bag rack.
4. The rest of the copper pipe is bent into a spiral shape and connected to the EVAPOT.

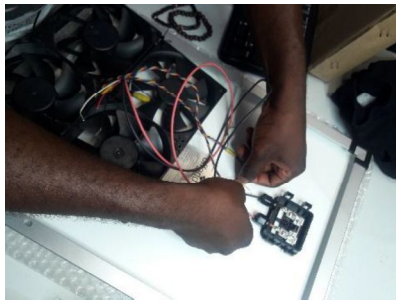

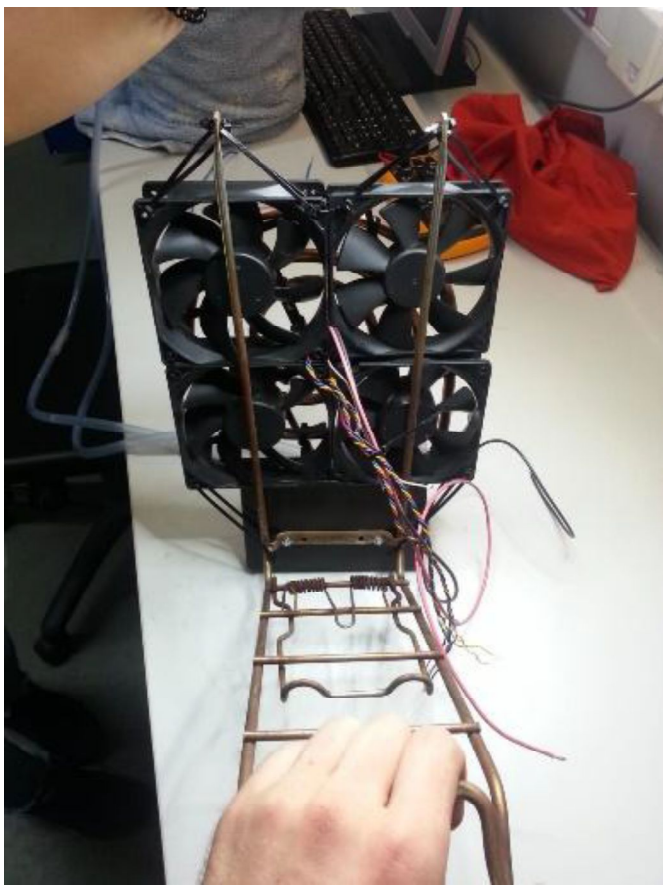
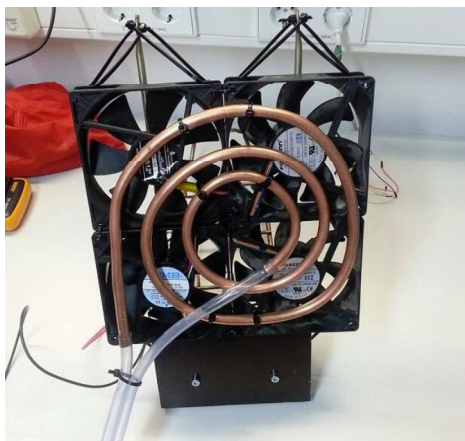

Water container and testing

1. A first aid kit box is used for holding the water container. The door of the box is removed.
2. All the gaps are sealed tight using silicone sealant.
3. The whole setup is then tested in the sun.

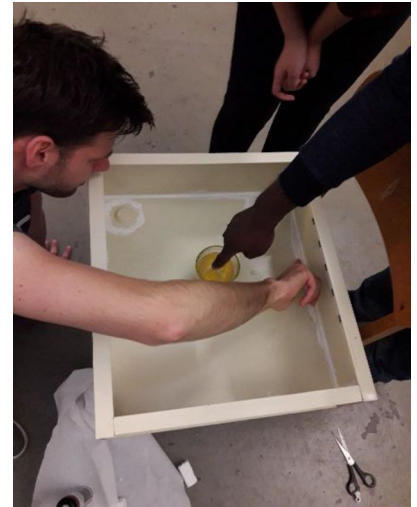
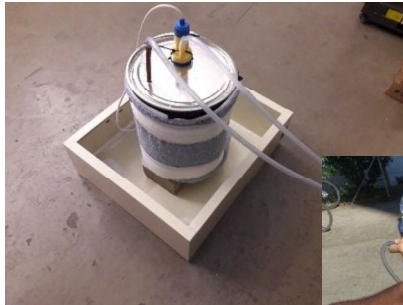

5. The Maker Faire

The last phase was to present our work at the Maker Faire. On 13th September we packed all of our projects into a van and transported everything to the Hannover Congress Centrum (HCC). Once there, we started setting up the stands and hanging the posters we had made. After that we filled the EVAPOT with water and ran some tests.



For the next three days, the fair opened its doors at 9 am. A lot of people, including families, teachers and even makers from the faire, came by our stand. Most of them, especially the kids, were drawn to our project thanks to the cold air from the fan. They were really curious about everything and after hearing the explanation most people showed a lot of interest in our prototype. Some people even gave us suggestions on how to improve it.



It was an unusual and fun experience to participate in the Maker Faire.

This whole project has certainly been a time to remember with wonderful people.



Projects built in Saint Petersburg

Team Members

Andrei Dolgirev
Alexandr Demchenko
Darina Shulepnikova
Natalia Maltseva
Savelii Dudoladov
Anastasia Markova

EVAPOT

Evaporative Air Cooler

COOL AIR

EVAPORATION

INTERNATIONAL Design Products 2018

DESIGN PRODUCTS 2018

DAAD | POLYTECH

MINDMETER

I'm a Jedi!

Look! I made it!

I'm trying my best!

I'm trying to concentrate!

Oh, there's butter!

SHUTTLE TRAINER

POWER STATION

BEATING HEART HEADBAND

BEATING HEART HEADBAND

STRASSBURG STATE POLYTECHNIC UNIVERSITY

Strategic Partnership 2013 - 2018

Financed by

DAAD

Federal Ministry of Education and Research

...g a number of jo...
 ...ams
 ... student mobility
 ...g joint PhD progr...
 ... young scholars a...
 ...g joint research pro...
 ...g research projects
 ...tise
 ...g research consortia f...
 ...ication submission
 ...ing joint summer schoo...
 ...ures
 ... participation in internat...
 ...d conferences
 ...t publications
 ...ademic and administrative
 ...provement of international
 ... program administration

1. Power Station

Power Station is a smart device which can be used in public areas to make mobile charging more convenient. You can rent a fully charged powerbank from this station and have freedom of movement with it. It can be used in airports, train stations, supermarkets, etc. You don't have to be "socket-dependent" or think about charging your powerbank anymore.

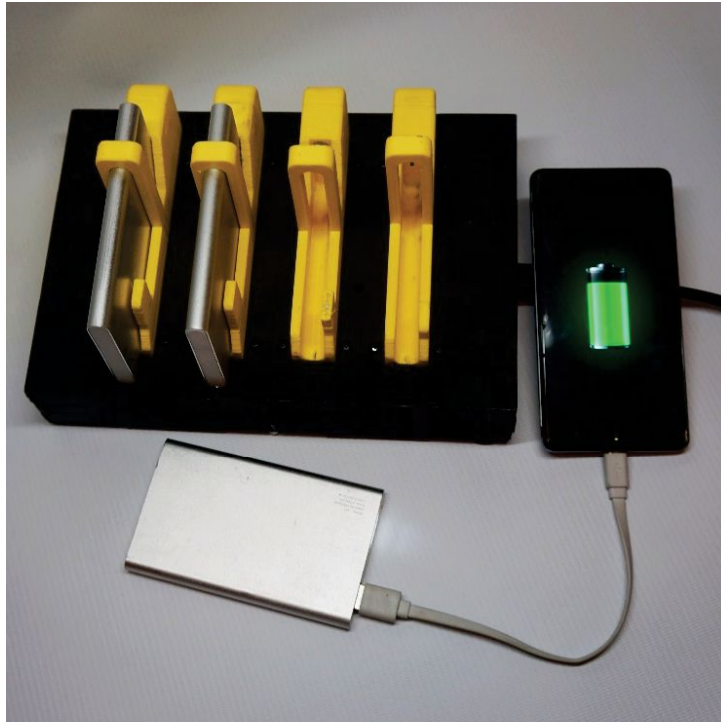

2. Headband

This stylish headband is a pulse-sensing wearable device with an LED heart that flashes to the beat of your own heart. We used ear clips and a pulse sensor to make it sensitive to your heart rate. The heart is displayed on an LED Matrix. Inside, there's a battery that you can easily recharge in 20 minutes.



3. Self-contained train

The project is called a self-contained train. It is a new generation locomotive for Russian Railways. It represents a new look for the whole railway industry. The train is completely self contained and is controlled remotely by a trained engineer. The software needed for the control is the "Remoutxy" app. This version of the self-contained train has been proposed and created by pupils and students using digital fabrication.



4. Braille trainer

This is a trainer apparatus which teaches you the braille script. Understanding of braille is one of the basic skills that allow people with a visual disability to be fully socially integrated. It is the understanding of braille that allows you to work on a computer, read books, and also navigate the world around you. Unfortunately, at the moment only a little more than 5% of people who are totally blind have this skill. These are mainly people with congenital visual impairment who have been trained in specialized institutions. People with visual disabilities who are blinded at a later time usually find it more difficult to master braille due to the lack of, or high cost of, training equipment. So it was for quicker and easier study of the braille script that this device was created.

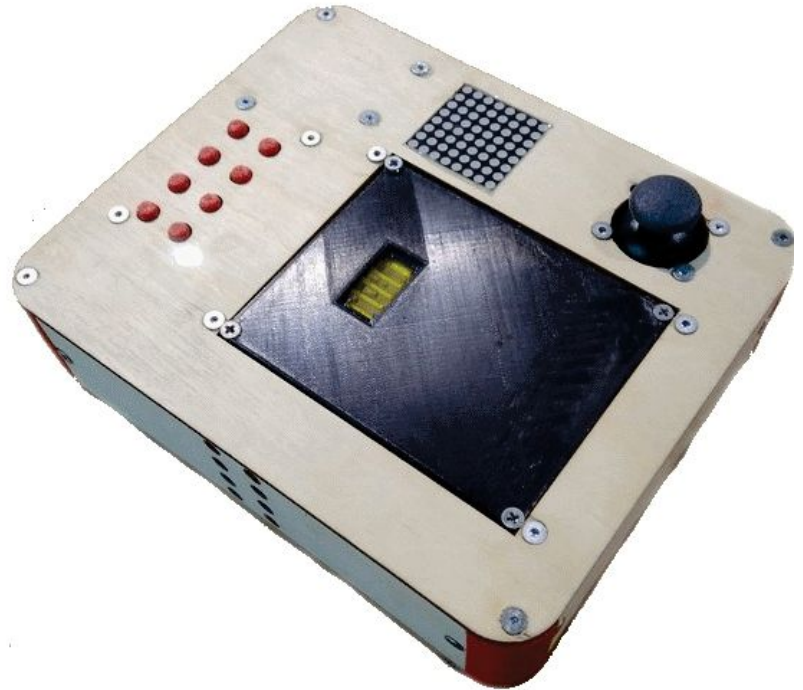

6. Solar charger

DIY set "Solar charger 5V". This set has been created for user enthusiasts, for master classes on renewable energy and for people who prefer to live in places far from sources of electrical energy. The solar charger created by us has a number of advantages over existing alternatives:

- 1) It is very simple to assemble.
- 2) It uses highly efficient solar panels of the latest generation with an efficiency of 20%, allowing charging to take place under conditions without direct sunlight.
- 3) The charger has an additional battery that allows charging in inconsistent illumination.
- 4) It has a low cost, low weight and is highly portable in a disassembled state – it does not take up a lot of space in a bag.
- 5) It has a number of mounts for placing it on various surfaces: for hanging, attaching to glass, and a stand for flat surfaces.

Despite its compact size and low cost, it allows you to charge smartphones or serves as a power source of 5V 2A, via a standard USB connector.





TO WEIGH 15KG

